

Boulder County
FLOOD PROTECTION HANDBOOK



January 2002



TRANSPORTATION DEPARTMENT

2045 13th Street

PO Box 471

Boulder, Colorado 80306

(303) 441-3900

PRSRT STD

US POSTAGE

PAID

PERMIT NO.



Board of County Commissioners

13th & Pearl Streets • Boulder County Courthouse • Boulder, Colorado 80302 • (303) 441-3500

December 20, 2001

Dear Resident of Boulder County;

You have this Flood Protection Handbook because you may be in an area subject to flooding problems. Flooding affects many residents of our county. Some experience fast-moving floodwaters when creeks or irrigation ditches overflow. Others have frequent, but slow-moving runoff water problems in their streets or yards during local storms. Some people have had repeated floods, while others have yet to be impacted.

Regardless of what you have seen, the next flood could be worse. We cannot ignore our flood risk. Floods take lives and damage property. They can be emotionally devastating to you and your family, both while they are happening and later when you have to deal with their aftermath.

The communities of Boulder County are working together to reduce the threat of stream and street flooding by building and maintaining flood protection works. However, flood control projects are very expensive, take years to complete, and will not offer 100% protection. We have a flood monitoring and warning program to provide advance notice of a pending hazard. We regulate new development to reduce flood impacts in adjacent areas.

While we are doing what we can, there are things that you can do, too. You can prevent future damage by floodproofing your buildings and making personalized flood preparedness plans. You can learn important flood safety rules and health precautions, and minimize your losses during flood recovery. This handbook was designed to help you do all those things. If followed, the guidelines will go a long way toward protecting your family and your home from the next flood.

If you would like to know more about what the county and your city or town is doing for public flood protection, please call the local floodplain contacts listed at the back of the handbook.

Sincerely, Boulder County Commissioners

Jana L. Mendez
County Commissioner

Ronald K. Stewart
County Commissioner

Paul Danish
County Commissioner

Acknowledgements

This manual was produced by Boulder County and the City of Boulder, Colorado. Funding was provided by Boulder County, the City of Boulder and the Urban Drainage and Flood Control District. We gratefully acknowledge the cooperation received from the floodplain staffs of the City of Arvada and Ft. Collins who provided samples of their flood manuals. The historic flood information was taken from the Emergency Operations Plan, jointly prepared by Boulder County and the cities of Boulder, Lafayette, Longmont and Louisville.

Significant contributions were provided by: Sylvia Dane and Gilbert White, Natural Hazards Research and Applications Information Center at the University of Colorado, Boulder; Clancy Philipsborn, Mitigation Assistance Corporation; Kevin Stewart, Urban Drainage and Flood Control District; Larry Matel, Pam Hanson and Anita Riley, Boulder County Transportation; Alan Taylor and Bruce Johnson, City of Boulder; Nancy Guynn, City of Lafayette; Kathy Ramberg, City of Longmont; and Mike Lutz, City of Louisville. We appreciate their thoughtful insights and suggestions, which have enhanced the quality of this publication.

The draft manual was also reviewed by the Advisory Committee, consisting of: Larry Stern, Boulder City and County Office of Emergency Management; Marilyn Galley, Colorado Office of Emergency Management; Fred Metzler, Federal Emergency Management Agency Region VIII; Robert Glancy and Treste Huse, National Weather Service; and Dr. Eve Gruntfest, Department of Geography and Environmental Studies, University of Colorado, Colorado Springs.

We are fortunate to have these dedicated experts reviewing and improving our emergency response plans. Thank you to each of these people for helping us to prepare for future disasters and to minimize our potential losses.

Dedication

We are people of our times, and our times have been altered forever by the terrorist attacks on the World Trade Centers in New York City and the Pentagon in Washington, D.C. on September 11, 2001. As a nation, we are more aware of the need to prepare for sudden tragedies and to protect ourselves through planning and vigilance.

We dedicate this manual to our heroes: the people who died in the airplanes and on the ground, their families, the fire fighters, police, military personnel, rescue workers, and the survivors. These individuals have shown brave and generous spirits, valuing life and facing death to preserve our freedoms. We honor each person who works to make our world a better place, one person and one day at a time. May each act of integrity and kindness be a living tribute to these heroes and their sacrifices.

HOW TO USE THIS HANDBOOK

- **If you heard a flood watch or flood warning, see Chapter 5: During the Flood.**
- **If you have just been flooded, see Chapter 6: After the Flood.**
- **If things are quiet and dry, see Chapter 3: Before the Flood to prepare a response plan.**

This handbook was prepared by Boulder County. Printed copies are available at various locations including:

- Boulder County Transportation Department
Boulder County Courthouse Annex
2045 13th Street, Boulder, CO 80306
- City of Boulder Planning and Development Services Center
Park Center Building
1739 Broadway, Boulder, CO 80306

Record your **IMPORTANT PHONE NUMBERS AND CONTACTS** on the page provided at the end of the text. This handbook will also be available on-line at **www.co.boulder.co.us**.

Photo Credits

Photos were provided courtesy of: the City of Longmont (front cover and p. 9), the City of Louisville (p. 1), and the Urban Drainage and Flood Control District (p. 8). Photos were also used with permission from the Roanoke Times & World-News (p. 4 and p. 6).

Disclaimer

This handbook is not intended to replace the advice and guidance of an experienced professional, who is able to examine a building and assess a particular situation. It contains general information based on current research and comments from experienced professionals. However, the reader must assume responsibility for adapting this information to fit his or her specific conditions. The reader is advised to seek professional assistance to evaluate or to repair extensive building damage, including related electrical components.

TABLE OF CONTENTS

Acknowledgements	ii
Dedication	ii
HOW TO USE THIS HANDBOOK	iii
TABLE OF CONTENTS	v
Chapter 1: Boulder County Flood Hazards	1
Local Causes of Flooding.....	1
Impact of Flooding.....	3
Chapter 2: Government Flood Programs	5
Public Information Programs.....	5
Flood Warnings.....	5
Emergency Operations.....	5
Flood Control Projects.....	6
Stream Maintenance.....	6
Floodplain Parks.....	7
Building Regulations.....	7
Flood Insurance.....	8
Other Programs.....	8
Chapter 3: Before the Flood	9
Flood Preparedness.....	9
Flood Response Plan.....	10
Insurance.....	11
Chapter 4: Floodproofing	15
Basement Cracks.....	15
Sump Flooding.....	16
Sewer or Septic System Backup.....	17
Barriers.....	21
Dry Floodproofing.....	22
Wet Floodproofing.....	23
Elevation.....	25
Relocation.....	25
Chapter 5: During the Flood	27
Flood Warnings.....	27
What You Should Do - In the event of a Flood Watch or Warning:.....	28
Turning Off the Utilities.....	29
Chapter 6: After the Flood	31
Step 1. Take Care of Yourself.....	31
Step 2. Give Your Home First Aid.....	32
Step 3. Get Organized.....	34
BOULDER COUNTY FLOODPLAIN CONTACT	36
WEBSITE ADDRESSES	36
Floodplain Contacts	37
IMPORTANT PHONE NUMBERS AND CONTACTS	39
Boulder County 100-Year Floodplain	42
Flood Safety Outdoors	44
Flood Safety Indoors	44

Chapter 1: Boulder County Flood Hazards

Many folks think that if they haven't been flooded yet, they never will be. However, it's just not so! Boulder County has been fortunate not to have had a major flood in decades. This chapter reviews the potential types of flood hazards and how a flood, worse than any you may have already experienced, could affect you.

Local Causes of Flooding

Many floods are caused by heavy rains, usually during summer storms. Sometimes, snowmelt adds to the amount of water runoff during a storm. This is especially common in mountainous areas. Creeks, ditches, and storm sewers can only carry so much water. Even in natural settings, creeks overflow every year or two when rains overload the channel. Flooding can be further aggravated when debris blocks the waterway.

Development has changed the natural environment within Boulder County. Pavements and rooftops mean that less rainwater can soak into the ground. Gutters and storm sewers speed the runoff to the

channels. Our pattern of streets and buildings has interrupted some of the natural drainageways and reduced the width of some channels. As a result, more water runs off more quickly, and the drainage system becomes overloaded more frequently.

The combination of heavy precipitation and an overloaded drainage system can result in three types of flooding: overbank flooding, irrigation ditch/canal flooding and street flooding. Each type of flooding is associated with somewhat different hazards.

Overbank Flooding

The most hazardous kind of flooding occurs when creeks and tributaries overflow their banks. The largest creeks in Boulder County are St. Vrain Creek, Lefthand Creek and Dry Creek in the northern part, and Boulder Creek, South Boulder Creek, Coal Creek and Rock Creek in the southern part. The most serious overbank flooding occurs during intense rainstorms or in a dam



Bridge south of Coal Creek Golf Course Clubhouse, May 1995

failure, resulting in a flash flood. A flash flood can occur very quickly. It is difficult to warn or protect against a sudden hazard of deep, high velocity floodwaters.

Historically, the most frequent flooding occurs in May and June, when snowmelt increases runoff. However, the most dangerous flooding events in Boulder County seem to occur from mid-July through September, due to heavy precipitation from thunderstorms. Creeks with mountainous, upstream watersheds are subject to flash floods and rarely have much time to evacuate. Colorado's worst flash flood occurred on July 31, 1976 in the Big Thompson Canyon, west of Loveland. That flash flood killed 139 people. Brief descriptions of some of the worst, recorded flood events within Boulder County include:

Boulder Creek

Boulder Creek has a long history of severe flooding. In June 1894, every bridge in Boulder Canyon was swept away during one of the largest floods. The floodplain was inundated by water over an area as much as one mile wide and eight feet deep.

South Boulder Creek

In the mountains west of Eldorado Springs, 6 inches of rain fell in September 1938. The flood destroyed many buildings in the community and exceeded previous flood records dating back to 1895.

Lefthand Creek

The June 1894 flood washed out bridges and roads near Lefthand Creek, as well as those near Boulder Creek. Buildings in Ward, Rowena, Glendale and all the towns along James Creek sustained heavy damage or were swept away. James Creek, a tributary of Lefthand Creek, grew to a width of 250 feet at some locations. Jamestown also suffered extensive flood damage in August 1913, and was isolated for two weeks when the access road washed out.

St. Vrain Creek

St. Vrain Creek flood accounts date back to 1844, with the largest flood recorded on June 2, 1941. Overbank flooding caused damage or destruction of homes, businesses, bridges, roads, water lines, crops, livestock and irrigation structures.

Irrigation Ditches/Canals

The eastern part of Boulder County has more than a hundred irrigation ditches and canals. They convey water collected in mountain reservoirs to downstream users. Ditches convey irrigation water **along** hillsides following contours, and as a result, cut across the natural drainage pattern of stormwater runoff flowing **down** hillsides. Every effort is made to separate stormwater runoff and irrigation water for ditch maintenance



Even shallow floodwaters can stop cars and wash people off their feet.

reasons. Excessive runoff may flow into an irrigation ditch, causing overbank flooding or collapse. Experience shows that there is little or no warning for this type of flooding.

Street Flooding

Except at underpasses, street flooding and yard ponding usually do not get deeper than a foot or two. Street flooding and yard ponding is often viewed more as a nuisance than a major hazard. It obstructs traffic and may mean that some streets have to be closed for a while. **Beware of the potential risk of entering any flooded area, especially one with moving water.** There can be high-velocity flows in areas with only shallow flooding. People and vehicles can be swept away by shallow moving water.

Impact of Flooding

If you haven't personally experienced a flood, it is hard to envision the severity of damage that it can cause. Flooding affects people and their property in many ways:

- Flooding presents a safety hazard to people and animals.
- Flooding causes health problems, both physical and emotional.
- Flooding damages buildings and landscaping.
- Flooding damages the contents of buildings.

Safety Hazards

Moving water causes more safety problems than standing water. Anything that is stored outside, and not securely anchored to the ground, can be carried away by floodwaters, i.e., toys, firewood, fuel tanks, structures, boulders, tools or vehicles. Floods become much more forceful as they accumulate debris. The debris can batter or impale people, as well as structures. Many of the bodies recovered from the Big Thompson Canyon flood were severely battered, and none of the fatalities were attributed to drowning.

Floodwaters can conduct electrical currents and hide debris. Be sure to look for potential electrical sources and stay away from any water in contact with them. Floods may structurally damage floors and stairs, making them unstable. Sometimes animals and snakes seek refuge in flooded homes or debris deposits, and may become hidden dangers.

Experiments at Colorado State University have shown that a person is less able to stand up in a flood as depth or velocity increase. They showed that a six-foot tall adult would be knocked over in four feet of water that is moving at a velocity of only one foot per second, or in one foot of water that is moving at four feet per second. Smaller people will have trouble in even shallower and slower floodwaters.

More people are killed trying to drive on flooded streets or bridges than in any other single flood situation. Cars can float in as little as 18 inches of water, and flooding may hide a washed out road with what appears to be only a few inches of water.

Health Hazards

Floodwaters are not clean. They carry mud, silt, road oil, and even sewage. Food, cosmetics, medicines, stuffed animals, baby toys, and any similar items that contact floodwaters, become contaminated and must be thrown out. Clothes and dishes need to be washed thoroughly in clean

water with soap to disinfect them. Mold spores and bacteria grow in damp areas and are difficult to remove completely. If a potable water system becomes contaminated, the health department recommends boiling all water to be used for drinking and domestic cleaning.

Floods also take a toll on people's mental health, caused by both the immediate dangers as well as future concerns. The stresses caused by flooding are aggravated by fatigue during cleanup and anxiety over lost income, health risks, and damage to irreplaceable items. Children and the elderly are especially susceptible to negative impacts from stress. Chapter 6 - After the Flood discusses ways of coping with these problems.

Building/Yard Damage

Standing water can seep through building walls, soak wood, dissolve wallboard and contaminate insulation. Electrical components may short when flooded, creating a fire or shocking safety hazard. If improperly dried, wet wood will warp and plywood will split, requiring replacement of stairs, flooring, etc. Mold is a big source of property damage, as well as being a health risk during floods.

As the water gets deeper, it puts more pressure on walls and floors, particularly in the basement. A flood that is over three feet deep will crack or break a standard house wall. Even very shallow flooding on the surface can put over seven feet of water pressure on a below-grade basement wall or floor, causing cracks, leaks, or even buckling.



Flooding affects property and people.

As discussed previously, moving water can transport debris from the ground surface as it flows downstream. The debris acts like a battering ram, capable of damaging or dislodging large structures, like buildings and bridges. It scours the ground, removing grass and plants and eroding channel banks. The flood becomes more destructive as it moves downstream.

Content Damage

Wet wooden furniture may be so badly warped that it can't be used. Other furnishings, like upholstery, carpeting, mattresses and books, are usually not worth the cost of drying them out and restoring them. Mold and mildew will quickly spread through the remaining debris. Flooded electrical appliances and gasoline engines won't work safely, until they are professionally dried and cleaned.

Chapter 2: Government Flood Programs

There are many existing, government-sponsored programs to prevent or reduce flood damage. You're not alone in tackling potential flood problems.

Public Information Programs

This handbook is only one of several ways to obtain flood protection advice. Current law requires that people purchasing flood-prone property be advised, in writing, of the potential flood hazard. Each year, the Urban Drainage and Flood Control District (UDFCD) sends notices to all district floodplain residents, reminding them of the potential flood hazard and suggesting ways they can protect themselves. The UDFCD is a metropolitan, special tax district that encompasses most of the towns and cities in the southeast quadrant of Boulder County. Additional flood related information can be obtained from the Internet sites listed near the back of this manual.

The Federal Emergency Management Agency (FEMA) prepares Flood Insurance Studies to map floodplains for counties and cities that participate in the National Flood Insurance Program (NFIP). Your local planning or building department, and the Boulder County Transportation and Land Use Departments use these maps to determine which properties are governed by floodplain regulations. Refer to the Building Regulations section of this chapter for more floodplain information.

Flood Warnings

The National Weather Service (NWS) and UDFCD monitor rain and stream gages. The NWS issues several types of flood notices directly to the Boulder City and County Office of Emergency Management (OEM).

The OEM coordinates the emergency response to all major disasters, including early flood predictions, the public Flood Warning Program and the Multiple Agency Coordinating System (MACS). It is the centralized source of disaster information for the public and the MACS emergency response agencies.

At best, a Flash Flood Warning can provide a few minutes of advance notice. This can be enough time for people to immediately move to a safe place on higher ground. Flash floods overflow embankments very quickly, and may occur without any warning. Stay alert to your surroundings. Refer to Chapter 3 to make a Flood Response Plan, and consult Chapter 5 for descriptions of different types of flood watches and warnings.

Emergency Operations

When the NWS issues a flood warning, the OEM activates the Emergency Operations Center (EOC) to respond to emergencies. Boulder County and most of its cities and towns belong to the MACS Emergency Preparedness Council, and share resources to respond to widespread emergencies. Periodic drills and real emergencies keep crew personnel ready to respond to floods and other disasters. The City of Boulder and Boulder County OEM tests its hazard warning sirens on the first Monday of April, May, June and July.



Drainage improvement project on Goose Creek at 28th Street, Boulder

Flood Control Projects

No city or county can stop flooding completely, and Boulder County is no exception. Flood protection is improved by installing larger culverts and bridges, armoring channels and embankments, and building retaining walls or earthen berms to redirect street flooding away from buildings.

Stream Maintenance

Accumulated debris and low tree limbs are removed to keep channels clear, especially at bridges and culverts, so stormwater can flow more readily along its drainage path. If you see debris clogging or other potential flood problems in local creeks, please report the condition to Boulder County Transportation Road Maintenance Division for rural (unincorporated) areas, or to the local public works department for incorporated areas.

UDFCD coordinates and funds flood control projects and maintenance programs to preserve floodplains within its boundaries. Its maintenance programs include: mowing and clearing debris, tree thinning and channel stabilization, and replacement of culverts, retaining walls, and other deteriorated structures.



Athletic Field Park in the St. Vrain Creek floodplain.

Floodplain Parks

One of the best ways to prevent flood damage is to keep the floodplain open. If there are no buildings in the floodplain, there will be little opportunity for property damage. Middle School and Heritage parks in Louisville, and Athletic Field and Loomiller parks in Longmont are examples of floodplain areas that have been acquired and kept open. They provide

recreational opportunities for the community and a place for temporary flood detention storage.

Building Regulations

Boulder County and most of its communities have adopted specific regulations to help ensure that new construction will not make our flooding problem worse. Construction is regulated on sites that are in floodways and floodplains. Only low damage potential improvements, that do not obstruct flood flows, are allowed in the floodway. A floodway is that portion of the floodplain with the greatest depth of inundation and the highest velocities. Floodway uses are limited to agricultural, parking, recreation, and similar open space uses, which will not increase the floodwater surface elevation. New buildings and substantial improvements to existing buildings in the floodplain must be built or floodproofed to one foot or more above the 100-year regulatory flood level.

Floodplain Mapping

Most flood construction projects and regulations are designed to protect people and property from the estimated 100-year flood, by keeping them out of harm's way. The 100-year flood has a one percent (0.01) probability of being equaled or exceeded every year. This is considered a cost-effective design standard for most construction projects, though some uses require different protection standards. Most 100-year floodplains on major drainageways have been mapped by the FEMA National Flood Insurance Program (NFIP). The NFIP Flood Insurance Rate Maps (FIRMs) are available for review at the Boulder County Transportation office, local building department or public library. FIRMs are available at the UDFCD office, or can be ordered through the FEMA publications office at www.fema.gov.

Floods larger than the 100-year design flood can and frequently do occur. FEMA is currently evaluating the need to revise its own standards and policies for floodplain zones with undesignated water surface elevations. FEMA updates the FIRMs as necessary, and requires floodplain developers to file Letters of Map Revision if they significantly impact the floodplain.

Municipal agencies and UDFCD continually evaluate and update their hydrology design standards based on historic precipitation and flood event records. Hydrology is the study of precipitation, storm runoff and the interactive effects of climate, topography, surface treatment and vegetation conditions. Communities may adopt more stringent floodplain regulations for proposed development than those adopted by FEMA.

A map of Boulder County 100-Year Floodplains is included on page 39 of this handbook. Although it should not be used to determine whether buildings are in or out of the floodplain, the map does give a general idea of what areas could be affected by overbank flooding. Check to see if your property is close to the mapped floodplain. If so, take a look at a more detailed map in the public library, or contact the Boulder County Engineering Division (303-441-3900) or your building/planning department to get more information on the flood risk in your area.

All construction projects in the 100-year floodplain need a county or city permit. This includes new buildings, garages, sheds, walls, fences or grading, as well as improvements to existing properties. If you see construction near a creek or channel without a posted permit, please report it to your building/planning division. Improperly constructed developments can obstruct flood flows or raise floodwater elevations, and increase the potential damage to your property or other locations near the floodplain.

There are different building regulations for developments located outside the floodplain. However, most construction projects must submit a storm drainage plan, to demonstrate that the proposed stormwater runoff will not overload the downstream drainage system.

Flood Insurance

Local building regulations are an important part of the NFIP program to make economical flood insurance available to the public. Boulder County and many communities participate in the NFIP Community Rating System (CRS). The objective of CRS is to reward communities that are doing more than meeting just the minimum NFIP requirements to reduce flood damages. This flood protection manual and testing the siren warning system in the spring are some of the activities that Boulder County sponsors to educate the public about emergency planning for floods. Boulder County develops land use regulations and prepares flood mapping to reduce the risk of flood damage, and consequently reduce the cost of local flood insurance premiums. Check with your building department to discover if your local government participates in the NFIP/CRS.

Other Programs

There are numerous other flood programs administered by state, federal, and private agencies. The U.S. Army Corps of Engineers provides technical assistance for reducing flood damages, planning assistance, and construction programs. The Colorado Office of Emergency Management, FEMA and the American Red Cross provide disaster response and assistance. The Colorado Water Conservation Board provides floodplain development regulations, and the Colorado State Engineer and Office of Emergency Management oversee dam safety design and inspections.

When these agencies provide emergency services, the work is usually coordinated by the local jurisdiction. A large collection of information about floods and emergency preparedness is maintained at the Natural Hazards Research and Applications Information Center at the University of Colorado in Boulder. To request information, call (303) 492-4181 or email www.hazctr@colorado.edu or www.colorado.edu/hazards.

Chapter 3: Before the Flood

The time to protect yourself from flooding is before the flood. There may not be enough time to prepare after you are notified of a flood watch or warning. This chapter covers three ways to do that: flood preparedness, flood response planning and insurance. A fourth way is floodproofing, which is covered in Chapter 4.

Flood Preparedness

Many preparations can be done prior to the next flood. The following checklist will help you prepare:

1. Determine how bad flooding could be on your property (see the guidelines in the box). Lists of resources and floodplain contacts are provided in the back of this manual.
2. Be familiar with official warning and evacuation procedures.
3. Purchase your own water alarm if your flooding comes from sewer backup or basement seepage. The alarm can give you precious extra time to minimize potential property damage. A water alarm is similar to a smoke alarm; it beeps when water touches it. Water alarms cost about \$15 and are available at hardware stores.
4. Talk to your insurance agent about your home owner's and flood insurance coverage. Consider separate flood and sewer backup insurance policies.
5. Prepare a list of emergency telephone numbers, including the number for your insurance agent. Make copies and keep them in your car, at work, or other safe location away from your home.
6. Assemble the supplies you will need for cleanup and recovery and put them in a safe place, above the expected floodwater elevation. Chapter 4 lists possible supplies.
7. Make a record of all your personal property. Go through your house room by room and make a household inventory. Take photographs or videotapes inside and outdoors. Inventory forms are available free from most insurance companies, or you can make your own.
8. Put photocopies of inventory records, insurance policies, deeds, automobile titles, wills, telephone numbers, bank and credit card account numbers, and other valuable papers at a location away from your house, and outside the floodplain, such as a safe deposit box.

KNOW YOUR FLOOD HAZARD

Ask the Floodplain Manager the following questions:

- How high would the 100-year flood be in my neighborhood?
- Can I expect fast-moving water, or water filled with debris?
- How much warning time can I expect?
- How will I get the flood warning?
- What streets are likely to be flooded or barricaded near my neighborhood?

9. Write a flood response plan and keep copies in your car and at work, near the utility meters, or other prominent places. The American Red Cross can provide a sample family response plan to get you started. Keep a copy of your response plan with this handbook too.
10. Check out the appropriate floodproofing options for your house in Chapter 4.

Flood Response Plan

Preparing a flood response plan will help you think through all the details that demand attention after a flood watch or warning is issued. Walk through your house with this handbook, and make notes of how to adjust these instructions to your own situation. Writing it down will help you remember everything, which is especially important when everyone is in a hurry and excited because of an imminent flood. Be sure to include **Important Phone Numbers** in your plan.

The flood response plan needs to be based on your own property's flood risk and how much lead time you have following a flood watch or warning. For example, **if you are warned of a life-threatening flash flood, you should get out of the area immediately**, without worrying about the backup power supply to your sump pump. Your plan should be a checklist of steps to take before floodwaters reach your house.

If you have only a few minutes following a Flood Warning, these activities might be on your flood response plan:

- Monitor Emergency Alert System (EAS) and local radio or TV stations for flood information and evacuation instructions.
 1. AM radio stations – 850 – KOA (EAS), 1490 –KBOL and 560 – KLZ, in Longmont 1060 - KLMO.
 2. FM radio stations – 95.7 - KHHH, 97.3 -KBCO and 88.5 – KGNU.
 3. TV broadcast stations – 2, 4, 7, and 9.
 4. TV cable station - 8
- Preplan two places where family members can meet if you are split up, one place in the neighborhood and another place that is out of the flood area. These places could be at friends' houses on higher ground, where family members can contact each other.
- If you leave, take your pets, medicine, and other things you will need if you can't return home for a day or two. Leave a note explaining where you have gone, when you left and how to contact you.
- If you leave, lock your house and follow your evacuation route to shelter.

If you have 15 to 30 minutes following a Flood Warning, include additional flood response activities like these:

- Read the safety precautions on the back cover of this handbook.
- Install flood shields and any other prepared floodproofing measures.
- Turn off the electricity and water if you anticipate that they might be flooded. If you are only subject to basement flooding, you can turn off the electricity to only that area and still have power in the rest of your house. When you prepare a response plan, mark your fuse box or breaker box to show the electrical circuits that serve the basement.

- **If you turn off the gas- you need to contact the utility company to turn the gas on and relight your furnace pilot light. You must determine if shutting off the gas is necessary.** Fortunately, you can preplan your intended response to different conditions when you prepare an emergency response plan.
- Test the backup power supply to your sump pump.
- Move the most valuable or damage-prone contents in your house to above the flood level or to another safe place. These include small carpets, lower drawers to dressers and cabinets, and cleaning fluids or hazardous chemicals. They can be moved to the upper story of your house or placed on top of cabinets, if floodwaters will not be that deep.

While you're working on a flood response plan, think about the other types of emergencies you might face, such as fires and tornadoes. The Boulder County Sheriff's Emergency Management and Public Safety Office (303-441-3390) and the American Red Cross (303-722-7474) can help you with ideas to include in a flood/disaster response plan. Supply lists for disaster kits and planning materials are available in your local public library, county or city emergency management centers, on the Internet at www.fema.gov and at American Red Cross offices.

Insurance

Flood insurance is highly recommended if you live near a floodplain, especially if you don't floodproof. An advantage of insurance is that your property is covered as long as the policy is in force, even when you're not home to implement your flood response plan. Most standard homeowner's insurance policies do not cover a property for flood damage. Here are three ways you can insure your house and contents for flood damage, in case state or federal disaster funds are unavailable.

National Flood Insurance Program

Boulder County, the cities of Boulder, Lafayette, Longmont, Louisville and many towns within the county participate in the National Flood Insurance Program (NFIP). Local insurance agents can sell a separate insurance policy under rules and rates set by the Federal Insurance Administration. Any insurance agent can sell a NFIP policy, and all agents must charge the same rates. Ask your agent to call 1-800-427-3880 for more NFIP information. Premiums are set on a national basis, and will not increase because you file a damage claim.

Coverage--Any walled and roofed structure can be covered by a flood insurance policy. Detached garages and accessory buildings are covered under the policy for the lot's main building. Separate coverage can be obtained for the building's contents (except for money, valuable papers, and the like). Renters may purchase contents coverage. The structure generally includes everything that stays with a house when it is sold, including the furnace, cabinets, built-in appliances, and wall-to-wall carpeting. Coverage is unavailable for things outside the house, like the driveway and landscaping.

Basements--The NFIP considers any below grade floor as a basement. For example, the lower level of a split-level house is considered a basement and so is a crawlspace. A National Flood Insurance policy does not cover damage to most contents in a basement. Structural coverage only covers the structural parts of basement walls and floor (not finishings like wallpaper or paneling), and selected items such as the furnace, water heater, washer, and sump pump. The NFIP does not insure buildings for subsurface flooding, including groundwater seepage or sewer backup.

Mandatory Purchase--If you are located in a "Special Flood Hazard Area" identified on a FIRM, you must buy flood insurance coverage as a condition for obtaining a federally backed mortgage, home improvement loan, or federal disaster assistance. In some cases, a private flood insurance policy will satisfy this requirement, but usually the lender or granting agency will ask to see an NFIP policy.

Waiting Period--There is a thirty-day (30) waiting period before NFIP flood coverage takes effect. Don't wait for the next flood watch to buy insurance protection. Contact your insurance agent for more detailed information on rates and coverage for your specific property.

Cost--The cost of a flood insurance policy depends on the amount of coverage and the location of the house with respect to the floodplain. A building located outside the floodplain has less flood risk than a similar house within the floodplain, and will have a lower NFIP premium. Buildings constructed after the issuance of the initial FIRM for the community and elevated above the 100-year flood level may have lower rates than older structures. Pre-FIRM structures built below the 100-year flood level may have higher insurance rates because of their higher risk of flood damage. Premiums may be reduced by discounts based on the Community Rating System or by higher deductibles amounts.

The following examples of approximate insurance costs are based on a single-family house in a Zone A floodplain. FIRM maps describe Zone A as an area of the 100-year floodplain with undefined water surface elevations. The sample premiums compare a higher and a lower amount of coverage available for homes with and without basements. The sample annual premiums are those for \$250,000 of structural coverage, based on 80% of the building's replacement cost. The example for \$50,000 in structural coverage might be appropriate for partial coverage of a building subject to shallow, slow-moving water, located in the flood fringe. It would only provide actual cash value coverage to repair damages, and would not provide basement coverage. The cost of flood insurance is affected by various conditions and must be evaluated on a site-specific basis.

APPROXIMATE ANNUAL NFIP FLOOD INSURANCE PREMIUMS FOR SINGLE-FAMILY HOMES (2001)

	<u>In floodplain?</u>	<u>Structural coverage</u>	<u>Contents coverage</u>	<u>Annual Cost</u>
With basement	In	\$ 250,000	\$ 100,000	\$ 1785
--Pre-FIRM Only:	In	\$ 50,000	\$ 20,000	\$ 678
Without basement:	In	\$ 250,000	\$ 100,000	\$ 709
	In	\$ 50,000	\$ 20,000	\$ 365

Fixed policy fees are included in the premium examples; however, Community Rating System discounts have been excluded. Prices are to be used for comparison only and are subject to change and site specific adjustments.

NFIP flood insurance is available for buildings located outside the mapped floodplain. More than 30 percent of NFIP claims are filed for property located outside the mapped floodplain.

FEMA regulations prohibit basements in homes, located within the floodplain and built after the initial FIRM issuance date. The flood regulations are based on these original FIRM issuance dates for mapped areas within the county: Boulder County – 2/1/1979, City of Boulder – 7/17/1978, City of Lafayette- 3/18/1980, City of Longmont- 7/5/1977, City of Louisville – 5/4/1973, Town of Lyons – 8/1/1980. The most current FIRM maps may have later dates to show its last revision date.

Basement Backup Insurance

Several insurance companies have sump pump failure or sewer backup coverage that can be added to a homeowner's insurance policy. Contact your insurance agent for more information.

Private Flood Insurance

A few private insurance companies sell their own flood insurance policies, although the coverage and rates are different from the NFIP's. Some mobile home insurance covers flood losses. Make sure that your coverage won't be cancelled if you submit a claim.

Before the Flood

Chapter 4: Floodproofing

This chapter covers changes that you can make to your building or lot to prevent or reduce damage by floodwaters. This handbook can only introduce the topic. Before you invest much money in floodproofing, talk to an engineer or architect, an experienced contractor, or your local building inspection department. Floodproofing measures are explained in more detail in different media available from libraries or Internet sites.

Different floodproofing techniques are appropriate for different types of buildings and flood hazards. Use the following guidelines to select applicable techniques:

- **If you have a basement**, read about basement cracks, sump flooding, sewer backup, barriers and wet floodproofing.
- **If your house is on a slab foundation and the 100-year flood is estimated to be less than three feet deep on your first floor**, read about barriers and dry floodproofing.
- **If your house is on a crawlspace and the 100-year flood is estimated to be less than three feet deep on your first floor**, read about barriers, wet floodproofing, and elevation.
- **If the 100-year flood is estimated to be over three feet deep on your first floor or will include high velocities and/or debris flow**, read about relocation.

HELPFUL RESOURCES

Homeowners Guide to Retrofitting- Six Ways to Protect Your Home From Flooding, FEMA June 1998. An extensive review that discusses aspects of protecting an existing house from flood damage.

"Best Build 3: Protecting a Flood-prone Home," FEMA/National Association of Home Builders. A 30-minute video overview of floodproofing techniques.

Colorado Floodproofing Manual. October 1986. Colorado Water Conservation Board and Colorado Water Resource Research Institute, Colorado State University.

Flood Proofing—How to Evaluate Your Options, U.S. Army Corps of Engineers, July 1993. A guidebook on selecting the most appropriate and cost-effective flood protection measures.

Engineering Principles and Practices for Retrofitting Flood Prone Residential Buildings, FEMA-259, January 1995. A technical design manual of flood proofing techniques, with cost-efficiency tools.

Internet sites: www.fema.gov,
www.co.boulder.co.us,
www.colorado.edu.hazards.

It is important that people understand that the predicted 100-year flood elevation is only an estimate, based on current technical standards for hydrology. Many times the floodwater elevation is higher than anticipated due to larger storms, saturated ground from prior storms or large volumes of debris in the water.

Basement Cracks

Groundwater can seep into your basement around pipes or through cracks in the walls or floor. The seepage path may be difficult to determine if the walls have been covered with paneling or other finishing. The best way to deal with a groundwater problem is to waterproof the walls and

Floodproofing

relieve the water pressure through a footing drain system and sump pump. See next section on Sump Flooding.

Cracks can be repaired and the walls can be waterproofed from inside or outside. Waterproofing on the outside is more effective because groundwater pressure forces the sealer into the foundation. The best technique is to dig a ditch around the basement wall so that you can apply a commercial sealant to the exterior walls. This can be done by a handy person (many home maintenance manuals have instructions for this), or a commercial waterproofing company.

Precautions

Waterproofing alone is recommended only for groundwater problems. Surface water will put much more pressure on the building's walls and can even break them. If the building will be affected by surface flooding, the owner should also install a barrier and an underground drain.

There have been many instances of disreputable contractors doing basement waterproofing, because the work is hidden and sloppy work may not show up for several years. Therefore, ask the waterproofing supplier or company to provide references of buildings in your area that have used their material or technique – before you sign a contract.

Cost - \$10-\$10,000 or more.

A homeowner can seal up cracks from the inside with a tube of sealant. Using a commercial waterproofing company to completely seal the exterior of all the basement walls will cost more. Costs should be used as estimates only, as they can vary widely depending on location, size and complexity of the work.

Sump Flooding

Basement flooding caused by saturated ground can be corrected by installing a footing drain around the foundation. The drain collects groundwater and directs it to a sump. When the sump fills, water is pumped out to a drainageway or onto the ground away from the building. Depending on local conditions, the drain and pumping system may have to handle large volumes of water.

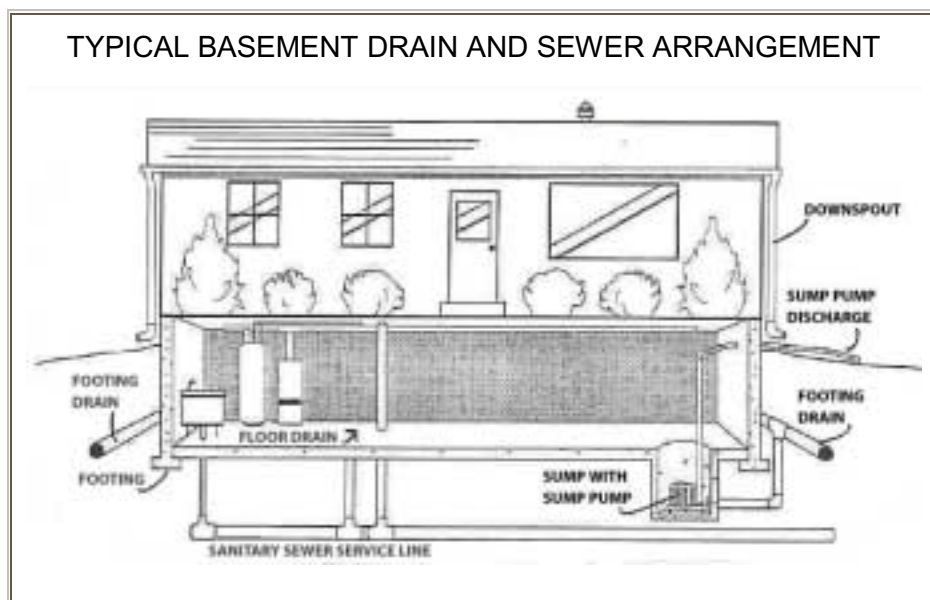

If the pump is blocked with debris, is overloaded or loses power, the system designed to keep groundwater out of your basement can act as a conduit to bring water in. You can prevent sump flooding by doing one or more of these floodproofing projects:

- Clean the pump intake to remove blockages,
- Install a larger sump pump, or add more pumps,
- Connect the pump to a backup power supply, like a battery system or generator,
- Disconnect the downspouts from the footing drain, or
- Redirect the downspouts and sump pump discharge farther away from the house.

Precautions

When the basement is full of water, it is hard to tell how it got in. It's a good idea to check for cracks in the walls and install sewer backup protection, too. Turn off the electricity before entering a flooded area. If your backup source of electricity is a generator, be sure it is set up outside or vent it to the outside to exhaust deadly carbon monoxide fumes. Set the backup power supply above the expected flood level.

Cost - 0-\$650

A homeowner can redirect the downspouts and sump pump discharge in a few minutes at no cost. An additional sump pump will cost around \$100, a battery backup system including a marine-style battery is \$350-\$450, and a standby generator can cost up to \$550.

Sewer or Septic System Backup

The previous illustration shows the sewer arrangements for a typical house with a basement. The sanitary sewer line drains toilet waste, laundry tubs, and the basement floor drain to the sanitary sewer main in the street or the septic system. Downspouts, footing drains, and sump pumps handle clean stormwater and groundwater.

Often basement flooding is caused by these two sewer systems being interconnected. Some houses have the downspouts, footing drain, and/or the sump pump connected to the sanitary sewer service. During a heavy rain, excessive amounts of stormwater can enter the sanitary sewers, causing backups into the house or overloading the treatment facility. For these reasons, interconnected sewers are prohibited in most jurisdictions. Clean stormwater should be discharged away from your foundation into drainageways, the street or the storm sewer.

Sewer system backups can also be caused by events not related to storms or flooding. Individual service lines can be plugged by grease, waste, tree roots, and breaks in the pipe or improper disposals. The owner or the utility can fix or prevent these problems by using proper maintenance, disposal procedures and planning. For example: Plant trees and shrubs at least 10 feet away from sewer lines to minimize potential root damage.

The following section describes ways to deal with sanitary sewer or septic backup that occurs when the downstream pipe is overloaded. There are four ways to stop sewer backup: Each of the following measures will prevent sewer backups in buildings with below-grade floors: a floor drain plug, a floor drain standpipe, an overhead sewer, and a backup valve.

Floor Drain Plug

The simplest way to stop sewer backup is to plug the opening where it first occurs. This is at the floor drain, the sanitary sewer system's lowest opening in the house. Commercial plugs are available that can be placed in the floor drain below the grate. Bolts on metal end pieces are tightened, causing a rubber gasket to expand and seal the plug in the pipe.



A plug stops water from flowing in either direction. Therefore, if the laundry tub overflows or other spillage occurs, it will stay in the basement unless the plug is removed. Because of this, it may be best to leave the plug out under normal circumstances.

One variation is a plug with a float. It allows water to drain out of the basement (see illustration, left). When the sewer backs up, the float rises and plugs the drain (see illustration, right). A permanently installed float plug will not interfere with the floor drain's normal operation.

Precautions

A plug left in the floor drain may contribute to a wet basement if spillage cannot drain out. Float plugs are known to jam open by a small amount of debris. A floor drain plug does not stop backup from coming out of the next lower opening, like a laundry tub or basement toilet. Sealing the base of the toilet to the floor will protect you until the water backs up higher than the top of the bowl.

A plug does not tell you if there is a problem in your sewer service line. If the plug is not tight enough, pressure can eject it. Increased pipe pressure may break the sewer lines under the basement floor if they are clay tile, but cast iron sewers are unlikely to break.

Cost - \$5-\$10

The great advantage of a plug is its low cost and ease of installation. A floor drain plug can be purchased at most local hardware stores or plumbing suppliers for \$5-10.

Standpipe

A standpipe is an inexpensive alternative to a floor drain plug. A "donut" with metal end pieces and a rubber gasket in the middle is placed in the floor drain. A length of pipe is placed in the "donut hole." Bolts are tightened and the metal end pieces squeeze the gasket to make a tight seal on both the floor drain and the pipe.

When the sewer backs up, the water stays in the pipe. Water pressure cannot build up to blow a standpipe (if properly installed) out of the floor drain. The system works unless the backup is so deep that it goes over the top of the pipe.

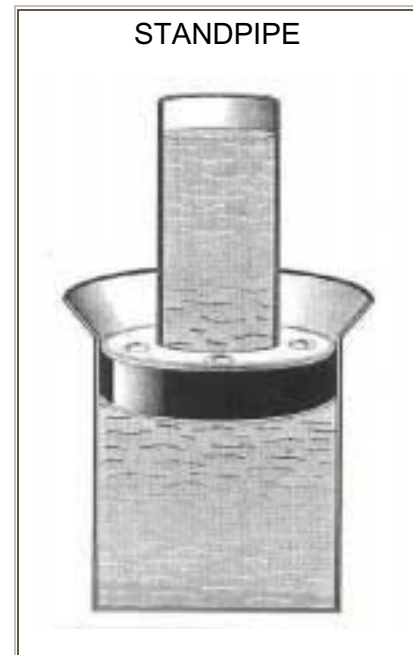

Precautions

A standpipe left in the floor drain may contribute to a wet basement if spillage cannot drain out. A standpipe only protects up to its height, normally three feet. Deeper flooding will flow over the top. A standpipe does not stop backup from coming out of the next lower opening, such as a laundry tub or toilet in the basement. Sealing the base of the toilet to the floor will protect you until the water backs up higher than the top of the bowl.

Because water pressure depends on the height of water in the pipes, a standpipe does not reduce the pressure in the pipes. Standpipes should be limited to three feet and are only recommended for buildings with cast iron sewer lines.

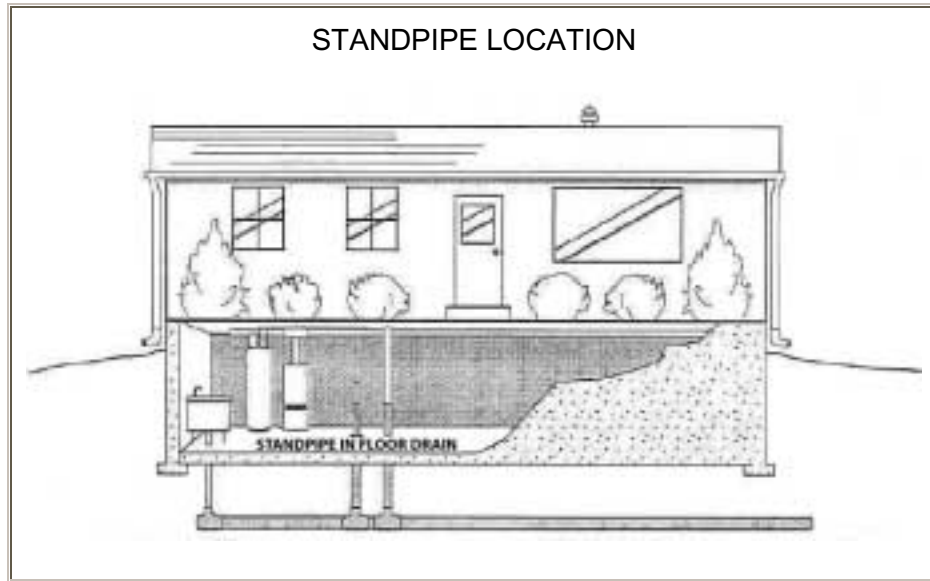

Cost -\$15

A standpipe "donut" and three feet of pipe will cost about \$15.

Overhead Sewer

An overhead sewer acts like a standpipe but without the problems. A sump is installed under the basement floor to intercept sewage flowing from basement fixtures and the basement floor drain. An ejector pump in the sump pumps sewage up above the flood level. From there it can drain by gravity into the sewer service line. Plumbing fixtures on the first floor will not be affected.

It is unlikely that sewers will back up above ground level. If water does go higher, a check valve in the pipe from the ejector pump will keep it in the pipes. Backed up sewage is enclosed in the sewer pipes so it can't overflow basement toilets or tubs.

Another advantage is that you don't have to be home during the storm because an overhead sewer is a permanent alteration to the plumbing. The only concern is that during a power outage, the ejector pump won't work. However, this only limits the use of the facilities in the basement that need the pump. The upstairs plumbing still works and the sewer is still prevented from backing up.

Precautions

This work requires a licensed plumber and a building permit. The ejector pump requires maintenance and electricity to work properly. The basement is disrupted during construction. The contractor may have to run the overhead pipes through one or more basement rooms. Care must be taken not to break existing under-floor sewers by increasing pressure too much, especially if the old sewer is clay tile.

Cost - \$2,000-\$6,000

Although more dependable than a standpipe, an overhead sewer is more expensive. A plumbing contractor must reconstruct the pipes in the basement and install the ejector pump.

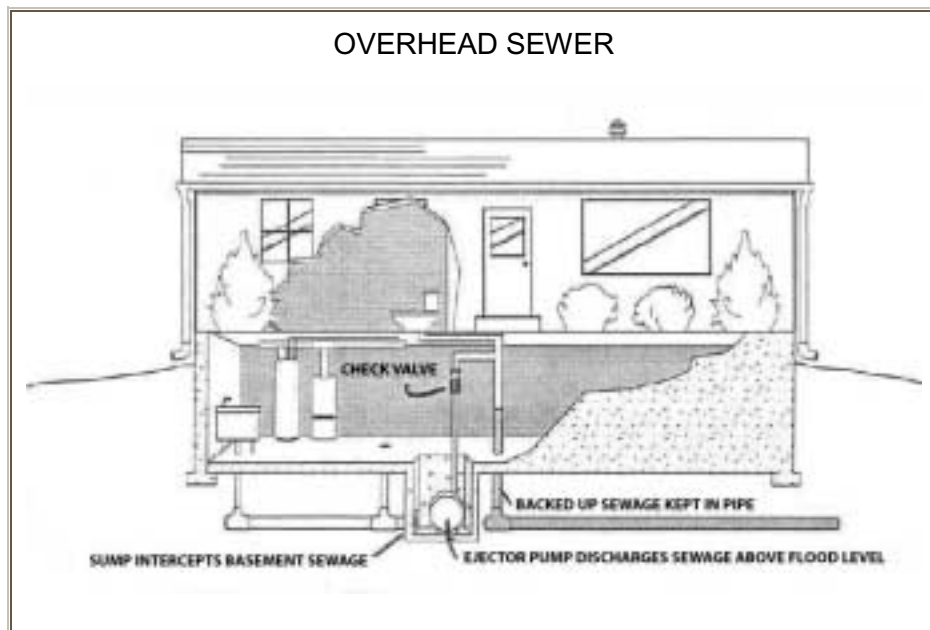

Backup Valve

Older versions of this approach were located in the basement and relied on gravity to close the valve. If debris was caught in the flapper, the valve did not close tight. Because of its unreliability, gravity backup valves were discouraged and even prohibited in some communities.

A newer "balanced valve" has corrected these design shortcomings. A system of counterweights keeps it open all the time so debris won't catch and clog it. When the sewer backs up, instead of relying on gravity, floats force the backup valve closed. It is usually installed in a manhole in the yard so there is less disruption during construction and no concerns over breaking the pipes under the basement floor.

As with overhead sewers, a backup valve is fully automatic. It can even work when there is surface flooding. The installation is outdoors, so there is minimal disruption of the basement during construction. It is best not to rely on the ability to use the sanitary sewers during flooding, because the sewer or septic system may be full downstream from the backup valve.

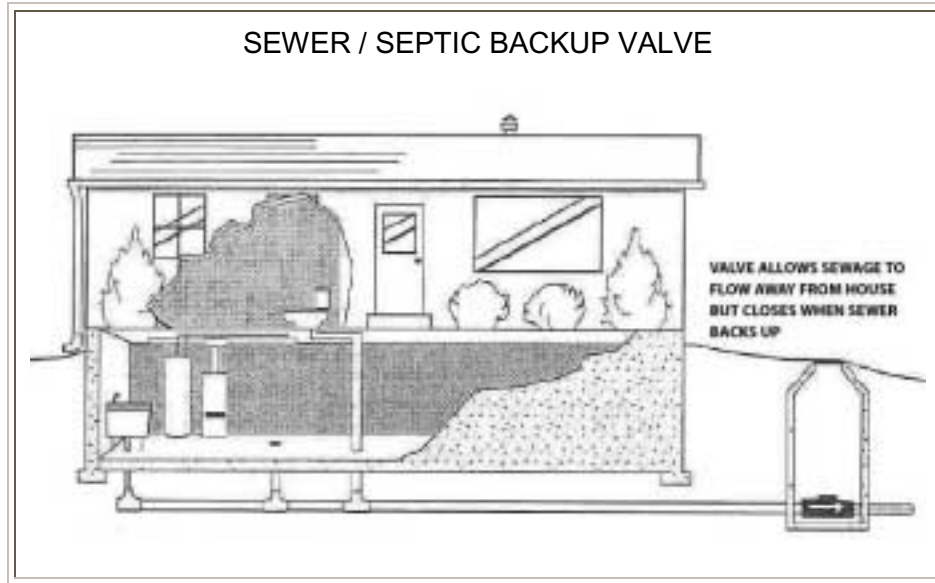

Precautions

The installation work requires a licensed plumber and a building permit. The ejector pump and the backup valve in the manhole will require maintenance. A manhole may be considered to be a potentially hazardous, confined space, and may require workers to take environmental safety precautions before entering.

Cost - \$4,000-\$5,500

The installation includes the cost of a manhole as well as the backup valve.

Barriers

Barriers keep surface floodwaters from reaching a building. There are three types: large engineered earthen levees, smaller earthen berms, and concrete or steel floodwalls. Barriers can surround the building entirely or connect to adjacent high ground.

Most earthen barriers are made from locally available fill. Their strength comes from their mass, so they need a lot of room. The standard design is three horizontal feet for each vertical foot (3:1 slope). As a result, you should plan on at least six feet of ground for each foot in height, plus the top width. A berm must be properly compacted and anchored in place to prevent sliding.

Reinforced concrete or steel floodwalls are used where there is not enough room for a berm or levee. Floodwalls must be watertight and properly anchored to withstand lateral hydrostatic pressure.

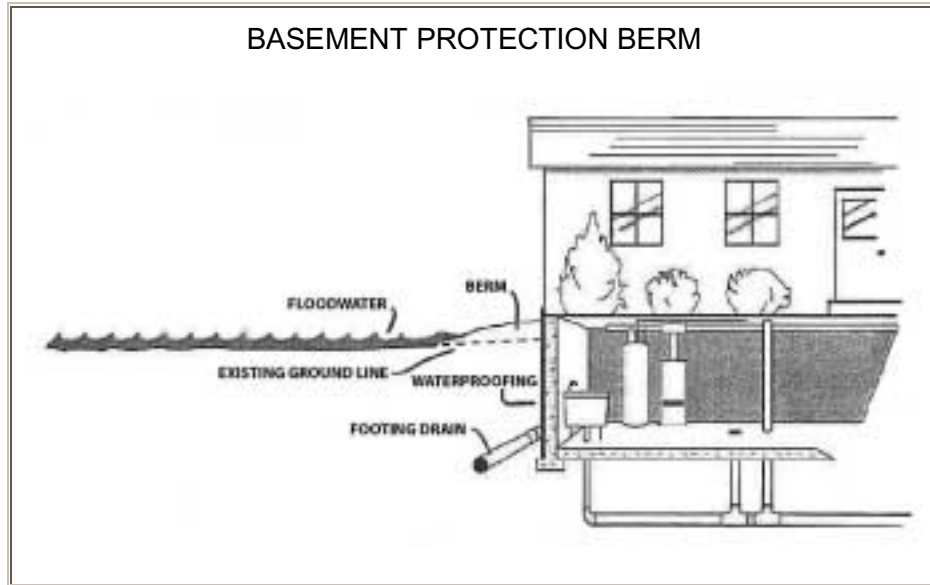

Depending on the soil porosity and the duration of flooding, your barrier may need a subsurface drain to handle leaks, seepage of water underneath, and rain that falls inside the perimeter of the barrier. You will need a sump or drain to collect the internal groundwater and surface water, and a pump and pipe to pump the internal drainage over the barrier.

For safety, non-engineered barriers should not exceed three feet high, since they pose potential risks due to sudden, catastrophic failure. Deeper flooding may be addressed better by wet proofing to save the structure. Any type of building can be protected with barriers, however buildings with basements will be more susceptible to underseepage. A levee or floodwall should be as far from the building as possible to reduce the threat of seepage and to reduce hydrostatic pressure on basement walls.

Precautions

Construction of barriers/berms, subsurface drains and floodwalls requires a building permit. These structures should be designed by a licensed engineer. Stormwater patterns cannot be diverted if the proposed discharge would negatively impact adjacent or downstream properties. An overview of potential stormwater impacts is necessary to prevent transferring drainage problems to adjacent properties.

Cost - \$0 - \$10,000

The construction cost can range from practically nothing if you regrade the yard yourself, to \$10,000 or more for a concrete floodwall three feet high with an underground drain and sump pump.

Dry Floodproofing

This term covers several techniques for sealing up a building to ensure that floodwaters cannot get inside it. All areas below the flood protection level are made watertight. Walls are coated with waterproofing compounds or plastic sheeting. Openings (doors, windows, and vents) are closed, either permanently, with removable shields, or with sandbags. A sewer backup protection measure is installed. All of the previously described flood protection methods belong to this category. Many dry floodproofed buildings do not look any different from those that have not been modified.

Floodproofing

Dry floodproofing is most appropriate for buildings on concrete slab floors (without basements) with no cracks, and subject to less than three feet of water. To ensure that the slab is watertight and sound, a careful inspection is recommended. A subsurface drainage system with a sump pump is needed in areas where waters will stay at flood stage for more than a few hours.

Precautions

A dry floodproofing project may require a county or city building permit. Footing drains should be designed and inspected during installation by a licensed engineer. Check with the Land Use or Building Inspection Division to be sure that your project does not violate any code requirements.

A building should not be dry floodproofed if floodwaters may be more than three feet deep or move faster than five feet per second. It is very tempting for the owner of a dry floodproofed building to try to keep the flood out, even if floodwaters get deeper than two or three feet. This can result in collapsed walls, buckled floors, and danger to the occupants.

Basements should not be dry floodproofed if the floodwater will touch the walls, because of the potentially destructive water pressure on the walls and floors. Basement walls can be waterproofed to protect them from high groundwater, if a footing drain is installed to keep the water pressure from building up. See the following section on Wet Floodproofing to protect subgrade foundation walls and floors.

Many commercial waterproofing compounds are made to protect wood from rain, but they will not withstand the pressures of standing water. Some deteriorate over time, so check with the supplier to be sure the waterproofing compound is appropriate for sealing your basement walls from water. Closing openings depends on having adequate warning time and having someone present who knows what to do.

Cost - \$100 - \$20,000

Dry floodproofing costs can range from \$100 when the handyperson simply applies a waterproofing compound, to \$20,000 for a more secure and attractive approach that works even when no one is home.

Wet Floodproofing

If floodwaters in your yard are touching the house, they are probably also seeping down between the soil and the exterior of the basement walls. Even if the outside water is only a few feet deep at the ground surface, it is putting pressure on the basement walls and floor equal to that of a standing body of water seven or more feet deep, about 750 pounds of pressure per square foot. A similar depth of dry soil exerts less than 100 pounds per square foot.

Most walls and floors are not built to withstand that kind of pressure. As a result, waterproofed basement walls and floors can be cracked, buckled, or broken by the pressure of floodwater. Instead of just a wet basement, you may end up with both a wet basement and broken walls.

One way to deal with this is to remove everything that could be damaged by a flood and let the water in. This is called wet floodproofing. Several modification methods can be used to minimize potential damage to the building and its contents if floodwaters are allowed inside. These techniques range from moving a few valuable items to higher elevations within the house to rebuilding the floodable area.

Floodproofing

In the latter case, structural components below the flood level are replaced with materials that are not subject to water damage. For example, concrete block walls are used instead of wooden studs and gypsum wallboard. The furnace, water heater, and laundry facilities are permanently relocated to a higher level. In the illustration below, these items are relocated to a small room added onto the house. Another approach is to raise these items on blocks or platforms where the flooding is not deep.

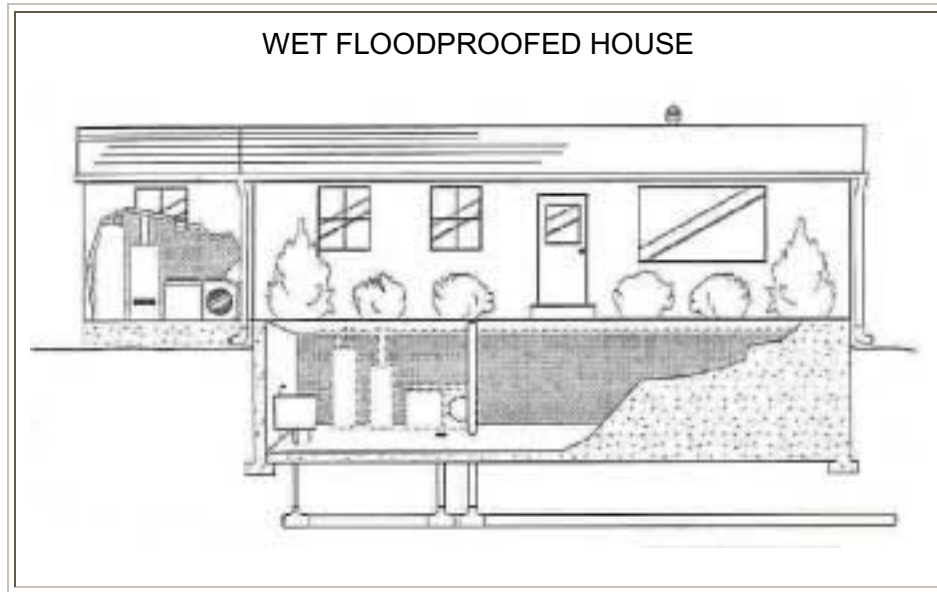

Many people wet floodproof their basements, crawlspaces, garages, and accessory buildings simply by relocating all hard-to-move valuables, such as heavy furniture and electrical outlets. Vents can be placed on the foundation walls to ensure that floodwaters can get into and out of the crawlspace to equalize water pressure on walls and floors.

Wet floodproofing has one advantage over the other approaches: no matter how little you do, you will reduce your damages. Simply moving furniture and electrical appliances out of the flood-prone area can prevent thousands of dollars in damage.

Precautions

Moving water lines or furnaces requires a building permit. Moving contents is dependent on adequate warning time and the presence of someone who knows what to do. Flooding an area where there is electricity, paint, gasoline, pesticides, or other hazardous materials can create a safety hazard. There will still be a need for cleanup, with its accompanying health problems.

Cost - \$0-\$20,000

You can accomplish some wet floodproofing, just by moving valuables and hazardous materials out of the floodable area. Reconstructing a floodable area with water-resistant materials and relocating utilities can be much more expensive.

Elevation

Short of removing it from the floodplain, the best way to protect a house from surface flooding is to raise it at least one foot above the 100-year regulatory flood level. This works well in flat areas with slow-rising water. The area below the flood level is either filled in or left with openings to allow floodwaters to flow under the building, causing little or no damage.

Many qualified contractors know techniques for elevating a building. The house will be jacked up and set on cribbing while a new foundation is built underneath. The foundation walls are raised to the flood protection level and the house is lowered onto the new foundation. Utility lines are extended and reconnected, steps are built, and, in some cases, the perimeter is backfilled or landscaped to mask the change. If the lower area is not filled in, it must have openings to allow water to flow under the building. This keeps the water pressure from endangering the foundation walls.

Where floodwaters are not very deep, the appearance of the elevated house is similar to that of a house on a two- or three-foot crawlspace. If the house is raised two feet, the front door would be three steps higher than before. If the house is raised eight feet, the lower area can be wet floodproofed for a garage or for storage of items not subject to flood damage.

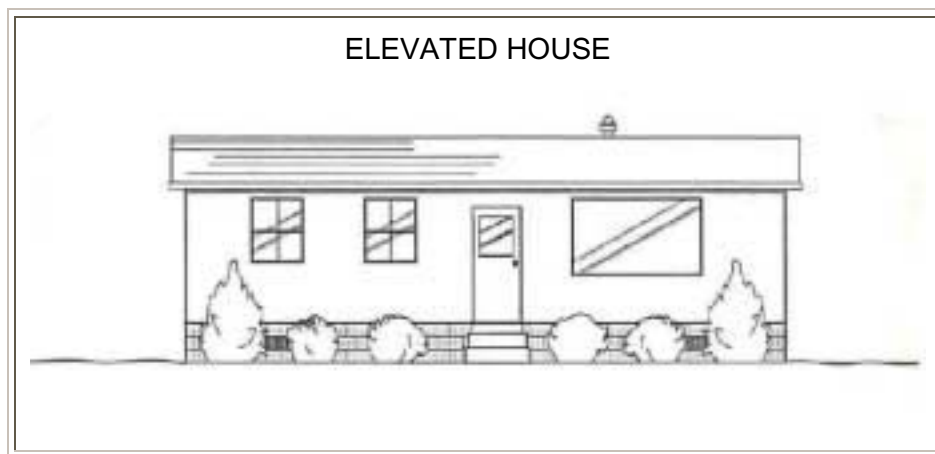

Precautions

Structural modifications require a building permit. The purpose of wet floodproofing is to minimize damage to the structure and contents by allowing the lower area to flood.

Cost - \$5,000 - \$50,000

Elevating a light weight building with a crawlspace ranges from \$15,000 to \$25,000, one with a concrete slab or masonry walls can cost \$25,000 to \$50,000. **This is the only floodproofing project that can lower flood insurance premiums within a floodplain.**

Relocation

The surest and safest way to protect a building from flooding is to move it to high ground. If your house is subject to deep flooding or high velocities, you should seriously consider relocating out of the floodplain. Several federal programs are interested in acquiring buildings that have been repetitively damaged by floods, or that are located in federally designated disaster areas. Often, the property acquisitions are a more cost-effective solution than paying repetitive insurance

Floodproofing

claims for flood damages. The community may have funds for additional properties, particularly if they are adjacent to parks or other public land. The property acquisitions can provide benefits to the community as well as the landowner.

Small, wood frame buildings on crawlspaces are easiest to relocate following acquisition. Larger buildings, those on slabs, or those built of masonry may be too expensive to move, and may be demolished after they are purchased by the community. The land can then be kept open for various public or open space uses in addition to flood conveyance and storage. Contact your local planning and land use office, if you are interested in pursuing this approach to reducing your flood hazard risk. Boulder County does not currently participate in any similar floodplain program.

Chapter 5: During the Flood

Storms and floods can occur very quickly in our area. You should be on the alert when you see storms brewing. When in doubt, turn on your radio or television and listen for weather information. Stay away from dry creek beds and drainageways.

Flash floods can occur at any time along the Front Range. In Boulder County, we have a flood warning system that should give you time to react. If you see flooding, please report it to the County so we can have a better picture of what is happening locally. Call the Boulder County Sheriff at (303) 441-4444.

Flood Warnings

The National Weather Service (NWS) issues three types of flood notices:

- **Flash Flood Watch** means river flooding or flash flooding is possible.
- **Flash Flood Warning** means flash flooding is imminent or occurring.
- **Flood Warning** means that river flooding is imminent or occurring.

Boulder County and City of Boulder Office of Emergency Management (OEM) works with the NWS to monitor conditions as they develop. If flooding is likely to occur, these agencies will issue flood warnings in many ways:

- NOAA Weather Radio. This is a radio station operated by the NWS on frequency 162.55 Mhz. You can buy a battery-operated weather radio at an electronics store for \$20-\$35.
- Local radio and TV stations. Most local radio and television stations will keep you posted on the flood status. See the Flood Response Plan and Contact List.
- Emergency vehicles. Sheriff, police and fire vehicles may be sent to the threatened areas. The emergency vehicles have sirens and mobile public address systems that will announce hazard warnings. They may tell you to evacuate. If so, follow their instructions and the

FLASH FLOOD SAFETY

- Flash floods can happen without warning. Have a plan!
- Know your flood hazard: If you are at home, at work, or in your car, know whether you could be affected by a flash flood.
- If it is raining and you are near a mountain stream, keep listening to a local radio or television station. If you hear a "flash flood watch" for your area, play it safe and move to high ground.
- ***If you hear a flash flood warning or a loud noise - Climb to higher ground immediately!***
- Leave your car and other belongings. You may have only moments to escape.
- Never try to drive or run downhill to outrace a flash flood. Avoid flooded areas and fast-flowing water. Do not try to cross flooded streams on foot or in your car. Roadbeds can wash away and 18 inches of water can carry away an automobile. Be especially cautious at night when it is harder to recognize flood dangers.

steps below. If there is no specific direction given, turn on your radio or television to find out what to do.

- **Communication signals may be blocked in mountainous areas.** Be aware of your surroundings. A rapid rise in water surface on a narrow canyon creek and a strange train-like noise may be your only indication of an imminent flash flood with a twenty-foot wall of water. ***Climb for your life!*** Think about it later!

The flood status will be updated on local radio and television stations. Once the agencies are sure that the danger has passed, they will issue an "all clear" message. You may not get a flash flood warning before flooding actually begins. Play it safe in stormy weather, be alert to conditions around you and read the next section.

What You Should Do - In the event of a Flood Watch or Warning:

1. Follow announced radio, television, or emergency vehicle instructions.
2. If a **Flash Flood Warning** was issued and you are in a mountainous area:
 - Climb to high ground as fast as possible.
 - Do not try to take your gear with you - your life is more important!
 - Do not try to run or drive downhill to outrace a flash flood.
3. Implement your flood response plan, if you have one.
4. If a **Flash Flood Watch** was issued, you may have time to prepare a flood response plan.
5. If a **Flood Warning** was issued and you are in the mapped floodplain:
 - Turn off the electricity and gas if necessary.
 - Read Flood Safety Outdoors on the back cover.
 - Lock your doors and evacuate to higher ground.
 - If you don't have a safe place to stay on high ground, listen to the radio or TV for information on public shelter locations.
6. If you are not in the mapped floodplain, it is unlikely that you will be flooded deeply. If the streets are flooding, you may be safer staying in your house.
 - Read Flood Safety Indoors on the back cover.
7. If you are not in the mapped floodplain, but your basement floods:
 - Turn off the basement electricity.
 - Turn off the gas, if you expect the pilot light to be flooded.
 - Move valuables upstairs.
 - Stay out of the basement, if floodwater is touching the house outside.

Turning Off the Utilities

Turning off your utilities could prevent greater damage if your building gets flooded. The illustration provides directions on how to do this safely.

Electricity

The most important utility to turn off is the electricity.

In case of a flash flood, it's more important that you get to safety quickly. Don't delay to shut off utilities.

Leave immediately for higher ground!

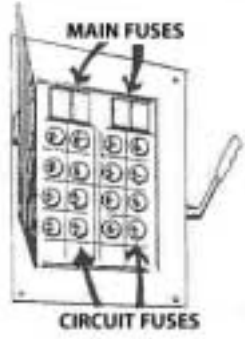
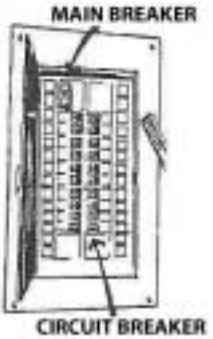
TURNING OFF THE ELECTRICITY	
	
Fuse Box	Breaker Box
<ol style="list-style-type: none">1. Make sure that you are not standing in water and that the box is dry.2. If your box has a handle on the side, pull the handle to "OFF."3. Open the box door.4. One or two large fuses will be marked "Main." Pull them out by their handles and put them in a dry place.	<ol style="list-style-type: none">1. Make sure that you are not standing in water and that the box is dry.2. Open the box door.3. One or two breakers at the top will be marked "Main." Switch them to "OFF."

Gas

Floodwaters may knock out pilot lights and silt may get into burners. If there is a chance that the pilot light could be flooded, you should turn off the gas before you leave to prevent a fire or potentially explosive safety hazard.

There is a valve next to the gas meter. If the valve handle is parallel to the pipe, the gas is on. **To shut the gas off**, turn the handle 90 degrees, a quarter turn, so the handle is perpendicular to the pipe. You may need pliers or a wrench to turn the valve.

Most gas meter valves have a hole in the handle that lines up with a hole in the valve body when the gas is shut off. This hole is used by the gas company to lock or seal the valve closed when the building is vacant. When the holes are lined up, you know that the gas supply has been shut off.

After the flood, contact your utility company to check the furnace, turn on the gas and reignite the furnace pilot light.

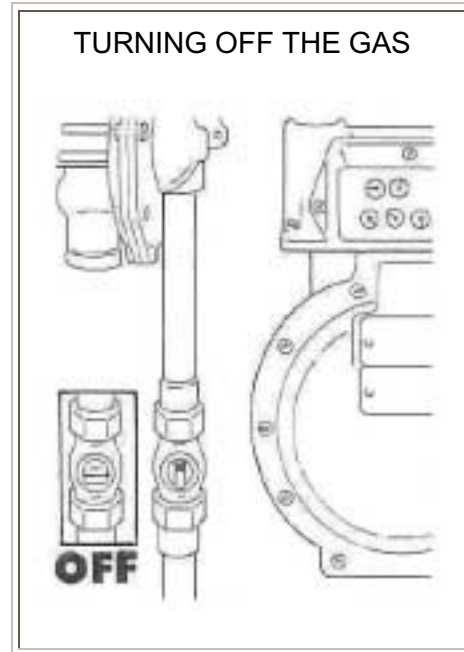

Fuel Oil Tanks

If you have a fuel oil or propane tank, turn off the fuel valve at the tank if the pilot light might be inundated or the supply lines might be broken by a flood. Make sure that your outdoor fuel tanks are securely anchored to the ground in flood prone areas. Propane tanks usually belong to the fuel supplier; ask the supplier how to properly secure the tanks. Contact your heating company or utility to check the furnace if it was flooded and to reignite the pilot light.

Water

Since your water faucets are usually turned off, you shouldn't worry about turning all the water to the house off during shallow flooding. However, if your washing machine is in the basement, or if the floodwaters around your house could be several feet deep, the floodwaters could get into the water lines through the appliances. Planning can help you to develop an informed, well thought out response to potential hazards – before they happen. If you have the time, turn off the water supply to the appliances or the house. There usually is a valve near the water meter or where the service line enters the house. The water valve has a handle, similar to a faucet knob. Turn it all the way clockwise.

Chapter 6: After the Flood

If you've been flooded, you should get a copy of *Repairing Your Flooded Home*, published jointly by the American Red Cross and the Federal Emergency Management Agency. Copies of the book are available free from the American Red Cross (ARC) Boulder County branch office at 5378 Sterling Drive, Boulder 80301, or call (303) 442-0577. The American Red Cross Mile-High Chapter can be reached through a 24-hour phone service at (303) 722-7474. Ask for publication ARC4477.

This chapter covers the three steps you should take the first few days after a flood. Additional steps are explained in *Repairing Your Flooded Home*.

Step 1. Take Care of Yourself

You and your family have been through a disaster. It has disrupted your life, and you must allow time for things to return to normal. You should recognize that the flood can take its toll on you as well as your property. You need to look after yourself and your family while you focus on cleanup and recovery.

Your hidden enemy is stress. Watch for signs of trouble like short tempers, getting upset over little things, having difficulty sleeping, bad dreams, aches, pains, stomach problems, apathy, and depression. These are ways your body tells you that times are difficult. Reactions to stress are common and usually temporary. Here are some things you and your family can do to relieve your tensions.

- Keep the family together. Togetherness provides mutual support.
- Discuss your problems. Talk to family and friends. Share your anxieties. Let others talk to you to help release tension. Crying is a natural response to a disaster. It's also a great way to release pent-up emotions.
- Rest often and eat well. You are more likely to suffer from stress and health problems when you are weak.
- Set a manageable schedule. Make a prioritized list of jobs to do one at a time.
- Watch for signs of stress. Signs of stress are often noticed by other people more readily than by the person experiencing the stress. Listen to them.
- Seek help. If you can't shake feelings of despair

HEALTH HINTS

- Wash your hands thoroughly. This is especially important before eating, cooking, or smoking.
- Confirm that the water is clean and safe. Don't drink it or wash dishes until you're sure.
- Disinfect dishes and all items that floodwaters touched.
- Watch out for fatigue. When your body is tired, you are more prone to accidents, back strain, and depression.
- Report health hazards. Call the Boulder County Environmental Health Department (303) 441-1180 if there are animal carcasses, rats, dangerous chemicals, or other health hazards on your property.

and stress, get professional help. Contact the **American Red Cross (303-722-7474)** or your local mental health clinic.

- Flood proof as you rebuild. Nobody likes being subject to the whims of nature. Preparing for a future flood can increase your sense of control over your destiny.
- Care for your children. Be understanding of their fears and stress. Avoid scolding children for behavior that might be flood-related, such as bedwetting, thumb sucking, or clinging to you. Remember, they are going through a rough time too.
- Stay healthy. When you work in an area that has been flooded, you probably will be exposed to dangerous chemicals and germs. Minimize contact with floodwater and debris by wearing protective clothing, like rubber boots and gloves, a mask or respirator.

Step 2. Give Your Home First Aid

Read the safety precautions on the back cover of this handbook. Each year more than 150 people die because of floods. Many of those fatalities are due to electrocution or other accidents that occur after the floodwaters have gone down. Your first job is to make sure everything is safe before you enter the area. Follow these steps:

1. Stay tuned to a radio or TV to find out when you can go back home. The county or city may issue special instructions or make building inspectors available to help you check out your house.
2. Check with your insurance agent to find out what cleanup and repair work is covered. This will help you to prepare a plan to restore your property.
3. Walk around the outside of your house and check for loose power lines and gas leaks. You can detect leaking gas by the putrid, rotten egg smell of chemicals that have been added to make a gas leak noticeable. **Report utility problems to XCEL Energy (303) 623-1234.**
4. Check the foundation for cracks or other damage. Examine porch roofs and overhangs to be sure their supports are structurally sound. Look for gaps between the steps and the house. If you see obvious damage, have a building inspector check the house before you go in. For help, call your local Building Inspection Division or in rural areas call **Boulder County Building Inspection Requests (303-441-3280)**.
5. Turn off the electricity at your house, even if XCEL Energy has turned off the main supply line (They may turn it back on when you're not ready). Call an electrician if you

THINGS TO TAKE WHEN IT'S SAFE TO RETURN

- Flashlight and batteries
- First aid kit
- Battery-operated radio
- Waterproof boots or waders
- Hard hat, boots with hard soles
- Camera or video camera to record damage
- Tools: crowbar, hammer, saw, pliers, etc.
- Drinking water
- Trash bags
- A wooden stick for turning things over and scaring away small animals
- Cleaning supplies:
 - Shovels
 - Buckets, hose
 - Trash bags
 - Mops, brooms, brushes
 - Rubber gloves
 - Rags
 - Cleaners and disinfectants
 - Lubricating oil

would have to go through water to get to your fuse box or breaker box, if the boxes are wet, or if you are not comfortable with electrical matters.

6. Turn off the gas only if necessary. **DO NOT ENTER AN AREA IF YOU SMELL GAS FUMES.** Call the gas utility from a safe offsite place to report a gas leak.
7. Go inside carefully. It may be easier to enter your house through a window if the door will not open easily. Look carefully at the ceiling, before you go in, to be sure it is not ready to fall. Do not smoke or use candles, gas lanterns, or other open flames until the house has been well ventilated. Turn on a flashlight before entering, as there may be explosive gases. **DO NOT ENTER AN AREA IF YOU SMELL GAS FUMES.** Alert someone outside of the house that you intend to enter, and ask them to call for help if you do not return or answer their call.
8. Photograph the flood damage for insurance reimbursement purposes, prior to beginning cleanup operations.
9. Rescue the most valuable items. Find and protect the "irreplaceables," like money, jewelry, insurance papers, photographs, and family heirlooms. Wash the mud off before it has a chance to dry. Wrap wet photographs and important papers in plastic bags and temporarily freeze them, until you have time to clean and dry them. Put sturdier items in a safe dry place, inside a plastic bag, or take them to a friend's home for safekeeping.
10. Keep the damage from getting worse. Open the windows and doors (if weather permits) to reduce the interior humidity and ventilate any odors or gas fumes. Check the basic structural integrity of the building before attempting to cover holes in the roof, walls, or windows with boards, tarps, or plastic sheeting to keep out the wind and rain. Save labor and material receipts for insurance reimbursement.
11. Repair sagging floors or roof sections. Use 4 x 4's or other heavy lumber to brace weak areas. If you are uncertain how to shore up floor or ceiling joists, call a contractor. Save labor and material receipts for insurance reimbursement.
12. Remove tree limbs or other trash that may have landed on or floated into the house. Save disposal receipts for insurance reimbursement.
13. Check for broken or leaking water pipes. If you find any, cut off the water supply by turning off the valve at your water meter. If

HOW TO DRAIN A BASEMENT

Follow these steps:

1. Make sure the electricity is off.
2. If there is no floodwater on top of the ground, start pumping the water out of the basement.
3. Pump the water level down two to three feet. Mark the level and wait overnight.
4. Check the water level the next day. If the water went back up, it is still too early to try to drain the basement.
5. Wait overnight. Then pump the water down two to three feet again. Check the level the next day.
6. When the water stops going back up, pump down another two to three feet and wait overnight. Repeat steps 4 through 6 until all water is pumped out of the basement.

the water pipes are not leaking, you can use your tap water for hosing things down and cleaning. However, do not drink or cook with tap water until the county or city declares it safe. If in doubt, call the water utility company.

14. Drain your basement slowly. The water in saturated ground puts tremendous pressure on your basement walls and floors. The water inside your flooded basement is counteracting this pressure. If you do not follow the instructions for emptying the basement gradually, your walls and floor may lose the support they need to counteract the pressure from the outside water. The weight of the saturated earth could then cause the walls to crack and collapse, buckling the floors and seriously damaging your home. Follow the checklist of steps provided to safely drain your basement.
15. Get rid of the mud and silt. Most of the health hazards brought by a flood are in the mud and silt that is left after the water drains away. Therefore, it is very important to clean it out as soon as possible. This is more effective if you do it before the mud dries out. Follow the steps below:

MUD REMOVAL TIPS

- First, shovel out the mud and move furniture and debris outside.
- Next, make sure the electricity is turned off. Remove all light bulbs from sockets that have been flooded. Disconnect and throw away flooded wall switches and outlets. They should be replaced later with new ones.
- Hose the house down, inside and out. If you have an attachment that sprays soap, wash and then rinse the walls and floors. Hose the opened electrical outlets, switch boxes, and light sockets.
- Do not let the water sit on the floor too long, especially if your floor is particleboard or another wood product that falls apart when wet.

Step 3. Get Organized

Before you try to clean up and repair everything, you need to assess your damage and develop a recovery plan. Follow the steps below to make the best use of your time and money.

1. Call your insurance agent. How much of your loss is covered will depend on your policy. Your agent will also tell you what to throw away, and what to save for the adjuster to examine. Find out if your insurance covers living expenses while your house is being repaired. If you do not have coverage, your agent can still advise you where to get help with cleanup and repairs.
2. Check for structural damage. Broken basement or foundation walls, shifted stairs, or slanted floors and walls could mean that these items will have to be rebuilt from the ground up. Repair safety hazards such as broken stairs before you proceed any further.
3. If you have structural damage, check with your local or County Building Department before you start any reconstruction or sign any repair contracts. You will need a building permit to repair structural damage. If the damage to your house's structure exceeds 50% of the value of your house, the federal government and the City's code will require you to elevate it above the 100-year regulatory flood level.

4. Ask the big question. Odds are that the area where you live will flood again. Before you spend a great deal of money and effort repairing and rebuilding, ask yourself, "**Do I really want to be flooded again?**" Study the floodproofing options in this handbook.
5. Start listing the damage. List the damage room by room. If possible, take pictures or videotapes of the damaged items as you clean up. Keep receipts for cleanup supplies, equipment rental, hired help, and temporary housing expenses. Keep a sample of items such as a piece of carpet to show the value of what you have thrown away. Good records are needed for insurance claims, applications for disaster assistance, and income tax deductions.

TIPS ON INSURANCE CLAIMS

- You are supposed to be reimbursed fairly for your loss, but you are not supposed to profit from a disaster.
- You cannot collect more than the face value of your policy, or for uninsured items, like landscaping.
- There are no financial incentives to encourage the adjuster to give you a small claim payment.
- Your adjuster will probably be from out of town. Get his or her name, company, and telephone number.
- In most cases you will be reimbursed for the actual cash value of an item, not its replacement cost.
- Your policy should list an office and telephone number to call with questions.

6. Make a recovery plan. A recovery plan is simply a list of jobs that need to be done. Planning can help you save time and money. Besides, being methodical and keeping everyone busy can ease tension. You will start seeing progress as you finish each project. Start making lists. Begin with the projects such as "replace furnace" and "dry the walls."
7. Decide what you can and cannot do yourself. You can save money by doing much of the cleanup and repair work yourself. However, jobs like shoring up broken foundations and replacing electrical service boxes are best left to the professionals. Save all receipts for material, equipment rental, labor and disposal fees for insurance reimbursement records.
8. Decide if you need financial assistance. After a flood, there are usually extra sources of help for the uninsured, if you need to replace items or hire a professional. Check the local newspaper, radio, and TV stations for notices about Red Cross, church, and government disaster programs. Even if you are insured, or think you can cover all your expenses, it makes sense to take advantage of whatever additional help is available. In the case of government assistance, you have already paid for it with your tax dollars and deserve a share of the funds set aside for disaster aid.
9. Keep the windows open as much as possible to begin drying out things.
10. Get a copy of *Repairing Your Flooded Home* from the American Red Cross. It will explain more steps to finish cleaning and repairing your building. If you have followed all the steps listed in this chapter, start with Step 4 in *Repairing Your Flooded Home*.

BOULDER COUNTY FLOODPLAIN CONTACT

Dave Webster, P.E., Floodplain Manager
Boulder County Courthouse Annex
2045 13th Street
Boulder, Colorado 80306
Phone: (303) 441-3900

WEBSITE ADDRESSES

Boulder County – www.co.boulder.co.us

Federal Emergency Management Agency -www.fema.gov

Natural Hazards Research and Applications Info. Center – www.colorado.edu/hazards

Urban Drainage and Flood Control District – www.udfcd.org

U.S. Army Corps of Engineers, National Floodproofing Committee – www.usace.army.mil

(SEE FOLLOWING PAGE FOR ADDITIONAL FLOODPLAIN CONTACTS)

Floodplain Contacts

INCORPORATED AREAS		
Boulder	Alan Taylor P.O. Box 791 Boulder, CO 80306	(303) 441-4232
Erie	Wendy Palmer 645 Holbrook Erie, CO 80516	(303) 438-6391
Jamestown	Eddie Ermoyian P.O. Box 285 Jamestown, CO 80455	(303) 938-9459
Lafayette	Nancy Guynn 1290 S. Public Road Lafayette, CO 80026	(303) 665-5506
Longmont	Kathy Ramberg David Hollingsworth 408 3 rd Street Longmont, CO 80501	(303) 651-8311
Louisville	Ken Johnstone Mike Lutz 749 Main Street Louisville, CO 80027	(303) 666-6565
Lyons	Theresa Andrews Clerk & Recorder P.O. Box 49 Lyons, CO 80540	(303) 823-6622
Nederland	Ron Trzepacz P.O. Box 396 Nederland, CO 80027	(303) 258-3266 Ext-22
Superior	Bruce Williams 124 E. Coal Creek Drive Superior, CO 80027	(303) 499-3675
UNINCORPORATED BOULDER COUNTY		
Boulder County Transportation	Dave Webster P.O. Box 471 Boulder, CO 80306	(303) 441-3900

IMPORTANT PHONE NUMBERS AND CONTACTS

Emergencies : Police, Fire and Ambulance.....911

- To report electrical or gas hazards, call XCEL Energy..... (303) 623-1234
- To report flooding, call Boulder County Sheriff..... (303) 441-3390
- American Red Cross, 24 hour line.....(303) 722-7474

Family Meeting Place_____

Alternate Family Meeting Place_____

- Non-Emergencies in Rural Boulder County:** Sheriff.....(303) 441-4444
- Immediate Communication for Health Hazards..... (303) 441-4444
- Health Hazard Complaints and Questions.....(303) 441-1190
- Building Inspection Requests.....(303) 441-3280
- Boulder County Transportation Department.....(303) 441-3900
- Boulder Emergency Alert System Radio, KBCO.....FM 97.3 and AM 1190

Local Non-Emergencies:

Emergency Alert System Radio_____

Police/Sheriff_____

Fire Department_____

Public Works Department_____

Flood Insurance Agent_____

Insurance Company Name /Policy No._____

Health Department_____

Call Building Inspection Division if you see construction near a creek or ditch without a permit posted. Call Street Maintenance Division if you see dumping or debris in a creek or ditch.

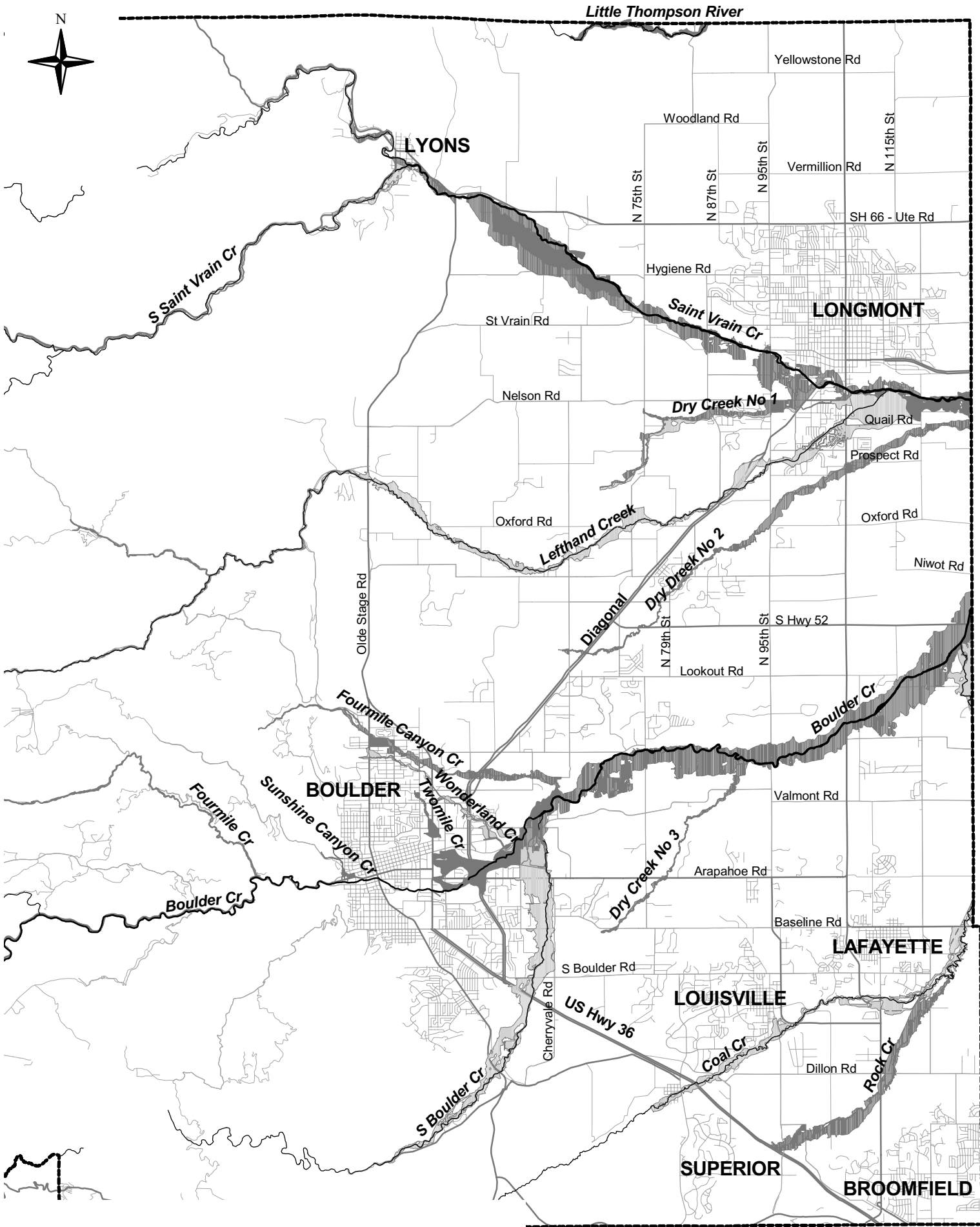

Boulder County 100-Year Floodplains

Flood Safety Outdoors

- **Do not walk through flowing water.** Drowning causes many flood deaths. Six inches of moving water can knock you off your feet. Use a pole to test the depth of standing water before you proceed.
- **Do not drive through a flooded area.** More drowning deaths occur in cars than anywhere else. Do not drive around road barriers as they indicate danger ahead. Two feet of water will carry away most automobiles.
- **Stay away from power lines and electrical wires.** Electricity can travel through water. Electrocutation is a major cause of death during floods. Report broken power lines to Xcel Energy (303)623-1234 or call 911.

Flood Safety Indoors

- **Turn off your electricity if your building is flooded.** Some appliances can shock you, even after they have been unplugged. Do not use appliances or motors that have gotten wet, unless they have been taken apart, cleaned and dried.
- **Watch out for hiding animals.** Small animals and snakes may seek shelter in your home once they've been flooded out of their own.
- **Look before you step.** Mud can be very slippery to walk on. Broken glass, nails and other debris may be deposited by receding floodwaters.
- **Be alert for gas leaks.** Leave the area immediately if you smell gas fumes. Use a flashlight to inspect for damage. Do not smoke or use open flames unless you are sure that the gas has been turned off and the area has been ventilated.
- **Carbon monoxide is deadly.** Only use a generator or any gas-powered machine outdoors in a well ventilated area. This includes camping stoves and lanterns. Fumes from charcoal grills are especially noxious, and charcoal-fueled grills must not be used indoors.
- **Clean everything that got wet.** Floodwater can be contaminated with sewage and hazardous chemicals. Do not consume anything that has contacted floodwater. Contaminated food, cosmetics and medicines are health hazards and must be disposed of. Before using, clean dishes and other washable items with soap and potable water.
- **Take good care of yourself and your family.** Recovering from a flood includes taking care of both physical and emotional needs. The psychological impacts of a disaster may last a lot longer than the physical impacts. Learn how to recognize and care for anxiety, stress and fatigue.